



The following instructions are for using Ambrosia Cropz Nutrients in a water driven injection system at an injection rate of 1:125 or 0.80%. (This will create a working solution value of 3.0 EC or 1500ppm). If you wish to adjust your EC up or down, do so by adjusting the injection rate on the water driven injectors. Remember to always adjust all three injectors equally up or down to maintain proper elemental balance.

\* (For use with water driven injectors with an injection range between 0.20%-2.00% or 7.5-75 ml/gal.)

#### VEGETATIVE GROWTH:

**Stock Tank 1:** 54 Gallons of H<sub>2</sub>O + 3 × 25 LB bags of Ambrosia Cal

**Stock Tank 2:** 54 Gallons of H<sub>2</sub>O + 2 × 20 LB bags of Ambrosia Mag

**Stock Tank 3:** 54 Gallons of H<sub>2</sub>O + 3 × 25 LB bags of Ambrosia Veg

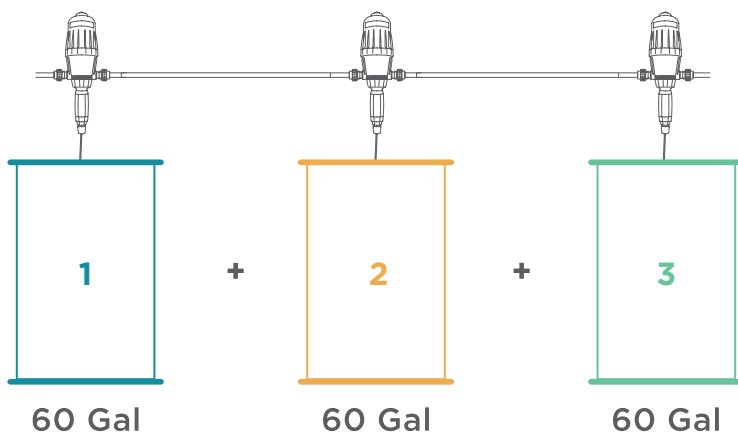

#### FLOWERING GROWTH:

**Stock Tank 1:** 54 Gallons of H<sub>2</sub>O + 3 × 25 LB bags of Ambrosia Cal

**Stock Tank 2:** 54 Gallons of H<sub>2</sub>O + 3 × 20 LB bags of Ambrosia Mag

**Stock Tank 3:** 54 Gallons of H<sub>2</sub>O + 3 × 25 LB bags of Ambrosia Flower

